



WM7617: Quad HD/SD Analog Video Decoder

WM7617 is a quad analog composite video decoding chip that supports both HDcctv and CVBS protocols up to 4-channel 4K@15fps. WM7617 converts the received high-definition analog composite video signal through analog-to-digital conversion, video decoding, and 2D image processing into YUV format, which is then transmitted to the master chip via the BT1120 or BT656 interface, enabling real-time preview and recording.

WM7617 supports bidirectional audio data transmission over a single coaxial cable, enabling voice intercom with remote cameras. It also supports bidirectional data communication with camera for remote camera control and firmware upgrades. By integrating video, audio, and control data transmission into a single cable, it simplifies wiring requirements and enhances the ease of installation and debugging.

WM7617 features an embedded audio codec with 5-channel Line-In and 1-channel Line-Out interfaces, enabling 5-channel analog audio capture and 1-channel analog audio output. This facilitates voice recording and intercom applications, simplifying product design.

Features	
VI	<ul style="list-style-type: none">● 4-channel analog composite video decoding● Supports 1M/2M/3M/4M/5M RT, 6M/8M NRT video format and CVBS format● Supports multi-channel video format● Supports manually extended video format● Embedded equalizer (EQ) amplifier for best extended reach performance● Programmable anti-aliasing LPF● High speed 10-bit Analog-to-Digital (ADC) for video signal sampling● Programmable clamp control
Video Decoder	<ul style="list-style-type: none">● Enhanced automatic format recognition for video signal identification● Supports AGC, ACC, White Peak● Brightness, saturation, contrast, hue, and sharpness adjustment● Advanced sync processor for best signal performance● Automatic frequency deviation compensation to accurate color demodulation● Integrated programmable high quality filter for Y/C separation
Audio	<ul style="list-style-type: none">● 5-channel analog audio Line-In with PGA and digital processing● 1-channel analog audio Line-Out with filter and gain control● Supports 8 or 16KHz sampling rate with a max resolution of 16-bit

Features

	<ul style="list-style-type: none"> ● Supports down-stream coaxial audio over video ● Supports programmable up-stream coaxial audio over video ● Up-stream sources from I2S, Line-In or cascaded input ● Cascade-able up to 4 chips ● Supports 1-channel I2S for audio record and 1-channel I2S for audio playback ● I2S support multiple channel output
VO	<ul style="list-style-type: none"> ● ITU-R BT.656/BT.1120 YUV422 output with embedded sync ● Supports flexible 2-channel multiplexed output on any BT bus ● Supports 4-channel multiplexed output on any BT bus ● Up to 8-channel video output with 4-channel multi-channel input ● Supports Y/UV swap on BT.1120 bus ● Supports programmable channel ID in multiplexed output ● Supports programmable clock delay characteristics for different chip interconnection requirements ● Supports single edge data output (SEDO) and double edge data output (DEDO)
Bidirectional Communication	<ul style="list-style-type: none"> ● Programmable up-stream data sending over cable ● Programmable down-stream data decoding ● Supports firmware upgrades for remote cameras

Peripherals

Video Interfaces	VI	● 4-channel analog video input
	VO	● 4-channel BT.656 or 2-channel BT.1120
Audio Interfaces	Line-In	● 5-channel
	Line-Out	● 1-channel
	Cascade	● 1-channel
	I2S	<ul style="list-style-type: none"> ● 1-channel for audio record ● 1-channel for audio playback
PTZ		● 4-channel
Other Interfaces		● Interrupt interface for video loss
		● I2C
		● 27MHz crystal or clock input

Physical Specs

Operating Voltage	<ul style="list-style-type: none"> ● 1.1V core voltage ● 3.3V I/O voltage ● 1.8V/3.3V HS I/O voltage ● 3.3V analog voltage
Package	● 14 mm × 14 mm LQFP128

WM7617 Block Diagram

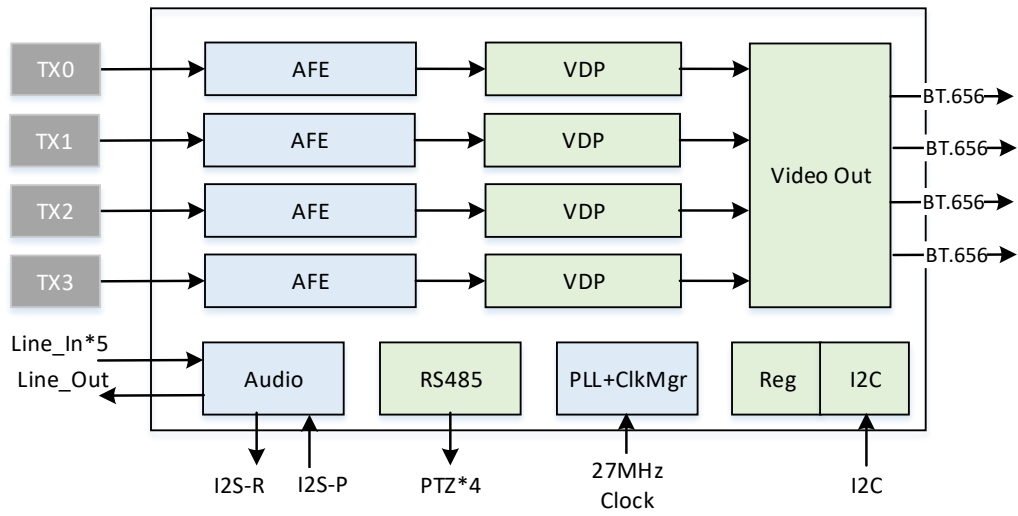

DVR Solution

